

G101Q9-A

10.1" Qualcomm® 6490 Rugged Robotic Controller



KEY FEATURES

- 10.1" 1920 x 1200 IPS LED Panel with direct optical bonding
- Qualcomm® 6490 (Octa-core 2.7 GHz) processor
- All-weather, dust, and water-resistant design (IP65). MIL-grade drop, Shock and vibration
- Supports WIFI, BT and optional 4G/5G
- With one removable battery

INTRODUCTION

Winmate's Rugged Handheld Robotic Controller Series is a versatile and durable solution tailored for robotics, defense, public safety, and industrial automation. Available in sizes from 5.5" to 10.1", these controllers support Windows, Android, and Linux, providing flexibility for various applications. Featuring IP65-rated water and dust resistance, along with MIL-grade shock and vibration protection, they are built for all-weather reliability. With PCAP touchscreens, Intel or ARM processors, Wi-Fi, Bluetooth, and optional 4G connectivity, these robotic controllers deliver robust performance in demanding environments.

OVERVIEW



Durable and High-Performance Design

The Winmate G101Q9-A Handheld Robotic Controller is engineered to deliver exceptional performance in challenging industrial settings. Powered by a Qualcomm® processor and running on Android or Linux Ubuntu, this device is optimized for applications requiring robust computational power. Its rugged construction meets IP65 standards for water and dust resistance and adheres to military-grade certifications for drop, shock, and vibration.

Uninterrupted Operation with Hot-Swappable Power

Equipped with a removable battery, the G101Q9-A ensures uninterrupted operations, even during extended use. The hot-swappable design allows users to replace the battery without powering down the device, making it ideal for critical applications that demand consistent uptime. This feature minimizes downtime and enhances productivity, particularly in field operations.





Seamless Connectivity Across Networks

Designed for seamless communication, the G101Q9-A supports WiFi, Bluetooth, and optional 4G/5G connectivity. These connectivity options provide reliable and high-speed data transfer, ensuring smooth integration with robotic systems and other industrial networks. This enhanced connectivity empowers users with real-time control and data access in diverse applications, from smart manufacturing to defense applications.

Tailored Configurations for Versatile Applications

Winmate offers a fully customizable robotic controller solution tailored to user-specific needs. The G101Q9-A supports various wireless modules and features a modular design with configurable joysticks, switches, and buttons. This flexibility allows users to adapt the device to different robotic systems and operational requirements, making it a versatile tool for modern industrial automation.



SPECIFICATIONS

Display			
Resolution	1920x1200	Size	10.1 inches
Contrast Ratio	800:1	Panel Brightness	800.0 nits
View Angles	85,85,85,85	Bonding	Optical Bonding for Sunlight Viewability
Type	Projected Capacitive Multi Touch	Viewability	AG+AF touch treatment
System Specification			
Processor	Qualcomm® 6490 (Octa-Core 2.7GHz)	Memory	6 GB
Storage	128GB	Operating System	Android 13.0
WLAN	Support	BT	Support
WWAN	4G LTE (Optional) 5G (Optional)	GNSS	GPS/GLONASS
Mechanical			
Dimension	317.75 x 188.87 x 35.8 mm	Cooling System	Fan Design
IO Ports			
USB Port	1 x USB 3.0 (Type-A) 1 x USB 3.1 (Type C)	Video	2 x micro HDMI output
Audio	2x Speaker	LAN	1 x M8 LAN Connector (10/100 Mbps , Max to 250 Mbps)
Environment			
Operating Humidity	10% to 90% RH, non-condensing	Operating Temperature	-20°C to 60°C (AC mode), -10°C to 50°C (Battery mode)
Storage Temperature	-30°C to 70°C (-22°F to 158°F)	Shock	MIL-STD-810H Method 516.8 Procedure I
Vibration	MIL-STD-810H Method 514.8 Procedure I	IP rating	IP65
Certification			
Certification	CE, FCC		
Control			
Button	2 x Toggle Switch 2 x joystick 2 x Roller switch 6 x buttons		
Power			
Battery	11.1V, typ. 6400 mAh Lilon Removable Battery (3S2P)	Power Rating	1 x USB (Type C) (Charging)
Adapter	PD Adapter 100W		
Accessory			
Accessory	1 x PD Adapter 100W 1 x M8 LAN external cable(2M) 1 x Power Cord	Optional Accessory	shoulder strap(Optional)

DIMENSIONS UNIT:MM

NOTE

1.This is a simplified drawing and some

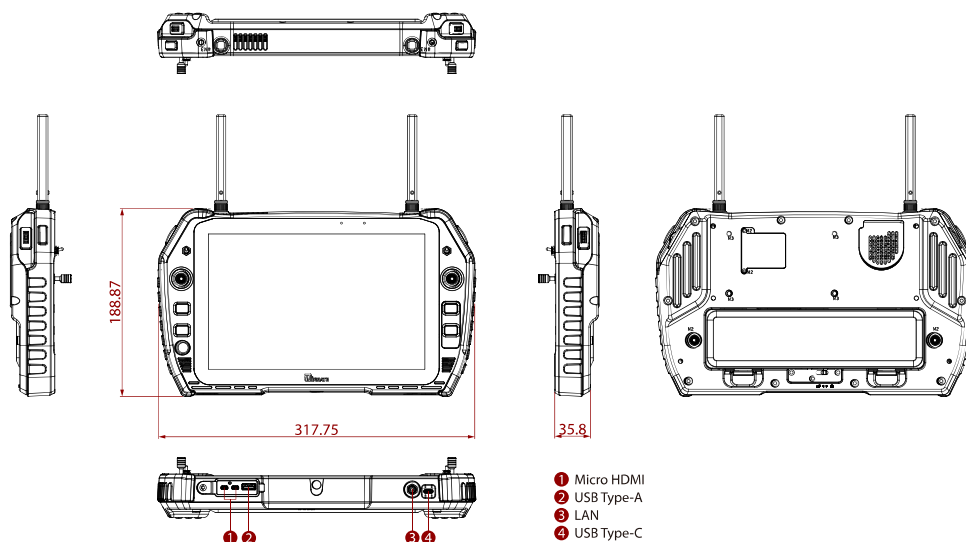

components are not marked in detail.
 2. Please contact our sales representative if you need further product information.
 3. All specifications are subject to change without prior notice.
 4. The product shown in this datasheet is a standard model. For diagrams that contain customized or optional I/O, please contact the Winmate Sales Team for more information.